

A laminated boat shelter

Steve Taylor of Steve Taylor-Builder, Inc. contacted us before undertaking a rather interesting project. He was about to build a boat shelter on an island in the St. Lawrence River. The design called for a row of curved laminated wooden struts, or columns supporting curved laminated tapered beams that would cantilever over the boat. The 25' tall, 60' wide structure would support a weatherproof fabric that would shelter both the dock and the boat.



Steve has built many high quality projects, but had limited experience in laminating. He asked the Gougeon Tech Staff to help him plan the laminating tasks this project required. The Tech Staff responded by devising ways for him to modify boatbuilding techniques for the architectural fabrication.

Steve wanted to know how many laminations or layers should be used. Laminates offer an advantage over solid material in that they randomly spread the flaws inherent in wood. More layers of thinner material are easier to bend. However, too many layers will drive up costs in a number of ways. They'll result in more machining scrap, require more handling and more gluing area. Also, with too many layers the stock becomes so thin that achieving even clamping pressure becomes more difficult.

Fewer layers of thicker material can result in spring back, or a relaxation of the curve of the laminate. Thicker pieces of wood also increase the chances of dimensional changes due to too much cross sectional mass. For this project, we felt each layer should be no thicker than 1". This meant eight layers for the columns and thirteen for the beams.

Choosing a wood species

Steve inquired about building the structure of white oak. Bonding white oak is always a little bit of a challenge no matter what adhesive is used. Better choices for a project such as this would be mahogany and Douglas fir. Both are pretty durable, dimensionally stable and look good when naturally finished. You can achieve a very attractive contrast by alternating light and dark colored wood species like fir and mahogany. He chose Honduras mahogany for this project.

Scarffing and tapering

The available mahogany stock was not long enough to make the 25' beams, so scarffing was inevitable. The first step was to bond shorter lengths together with 8:1 scarf joints to make thirteen full-length boards for each beam. The joints in each layer were staggered to avoid joints near each other in successive layers.



The beams were tapered in profile, and it is tough to taper a laminate with saws and planes. We suggested that they taper the individual laminate layers before laminating. That way, after gluing the layers together, only the sides of the beams would need to be planed. The resulting beams with their tapered layers would also be more aesthetically pleasing. In addition, less end grain would be exposed than if the top or bottom of the beam were sawed to shape after lay-up.

To taper the beams in this manner, Steve and his crew first had to figure the amount of taper in each board, from the thicker cross section in the middle, to the thinner sections at the ends. Next, they made a mirror-opposite master to represent this taper-thicker at the beam's ends and thinner at the beam's middle.

When the master was passed through a thickness planer with a scarfed together board on top of it, the planer removed more material from the ends of the board than the middle. All laminations were passed through a planer in this manner and all were tapered exactly the same.

The logistics of clamping

By using the proper clamping jig set up, Steve and his crew were able to laminate each beam in one operation. The same method is used to laminate ring frames for boats. First they covered their work surface with rigid plastic to prevent inadvertent bonding (soft plastic sheeting can become caught between laminate layers as they are drawn into shape). They described the outer shape of the beam with blocks fixed to a flat table. The thick laminate layers would have to lay straight when placed into the jig, then be forced to the designed curve.



To force the layers into place, they used a series of threaded rods mounted to short sections of angle iron. Each threaded rod ran through a nut welded over a hole in the vertical flange of the angle iron. The threaded rod had a flat pad on the end where it contacted the laminate. A nut welded to the opposite end of the rod allowed the crew to screw it toward the fixed pads describing the outer curve. Air wrenches sped up the process. Once the laminate was pushed into shape, they placed additional clamps as needed along the beam. Only modest pressure was required to draw the parts together and form a tight glue line.



The pictures show the stunning results of Steve Taylor-Builder, Inc.'s first major wood lamination project. After completion, Steve wrote to us and said "I want to thank you for your help and guidance with the tapering and fabricating of the frames, but most of all for your encouragement to do this ourselves. It was great fun and it is very satisfying to know that we can do such things."

From Epoxyworks 12, Fall 1998
(c) Gougeon Brothers, Inc.

More on laminating wooden beams

By James R. Watson

When I was a kid, my older brother had a slingshot that was fashioned from a tree crotch. The wood fibers neatly followed the desired shape and nicely addressed the forces when operated. Centuries ago, many large ship components-knees, hooks, and floors were selected from forks, crotches and crooks of trees for much the same reasons. One-piece wooden parts were very reliable and the naturally grown beams and frames were key components of ship construction. As the availability of large naturally shaped timber diminished, large curved components were made of stacked and mechanically fastened smaller pieces of wood. Laminated wood structures weren't possible until the relatively recent development of strong adhesives.

It is somewhat misleading to say that laminated wood superior in strength to solid wood. Wood fiber is wood fiber. What jeopardize strength and reliability of a one-piece beam are its inherent defects. Strength and stiffness would be predictable and reliable if flaws such as knots, grain runout, grain dive and pitch pockets could all be detected and evaluated. To compensate for the possibility of

hidden weakness designers are inclined to over-engineer by using heavier solid timbers. These days, the use of solid timber is limited to components that are mostly short and straight.

Laminating advantages

The reality of flaws in solid wooden components underscores the advantages of laminating wooden parts. With laminating, you can assemble the pieces, or plies, of a laminate stack to build a part to a specific shape (almost as if it grew to that shape)- orienting wood grain to address predicted stresses, minimizing waste, and reducing and dispersing flaws.

Joints can have the same effect as flaws in wood structures. The number of joints is often dictated by availability of good lengths of flawless timber. In solid wood components scarf joints are employed to join shorter timber end to end in an effort to maintain strength across the joint. Simpler joining methods such as butt joints require much less labor, but are much weaker and are stress concentrations.

Where butt joints may be out of the question for solid timber construction, laminating allows you to use butt joints, because each joint has less effect on the overall strength of the part and joints, like flaws, can be evenly distributed throughout the part.

Orienting wood grain

The load on beams and frames is generally unidirectional. The wood grain in both solid and laminated beams generally runs in one direction, parallel to the long axis of the beam. For structural components that do not carry a simple unidirectional load, laminating offers the opportunity to adjust the grain to the load direction. Although wood is much stronger along the direction of the grain, laminated wood can be made stronger across the grain by incorporating plies in directions other than the primary grain direction. By orienting every other layer 90°, plywood panels, for example, become stiff in two directions. While a strip of plywood would make a pretty poor beam, skewing laminations 5° to 10° from the long axis of the piece will improve crossgrain strength, but the piece would still be strong in the primary load direction. One advantage of skewing fibers at an angle is that it orients fibers more gradually throughout a bend, exerting less stress and allowing greater ply thickness.

Thinner is better

Choose the wood for a particular structure or part based on strength, stiffness, weight, cost, availability, the builder's abilities, bondability and workability. All materials have a maximum bending radius-before compression or tension damage begins. If the wooden ply will not negotiate the bend at a given thickness, then thinner material is required. Thin materials negotiate a bend more easily than thick ones and more laminations of thinner material better resist springback.

Also, when wood is sliced into thin plies, trapped stresses are relieved; when bonded back together the resulting laminate is more dimensionally stable-able to resist the swelling, shrinking or warping that a thick one-piece component may produce (especially when exposed to fluctuations in humidity.) A good example of the value of thin laminations is in a guitar neck where stability translates into more consistent tuning.

Variations that improve basic laminating

As with any technique, there are variations of basic methods that can improve wooden laminates:

1. Improve the strength-to-weight ratio by placing higher density wood furthest from neutral axis and lighter density close to neutral axis.

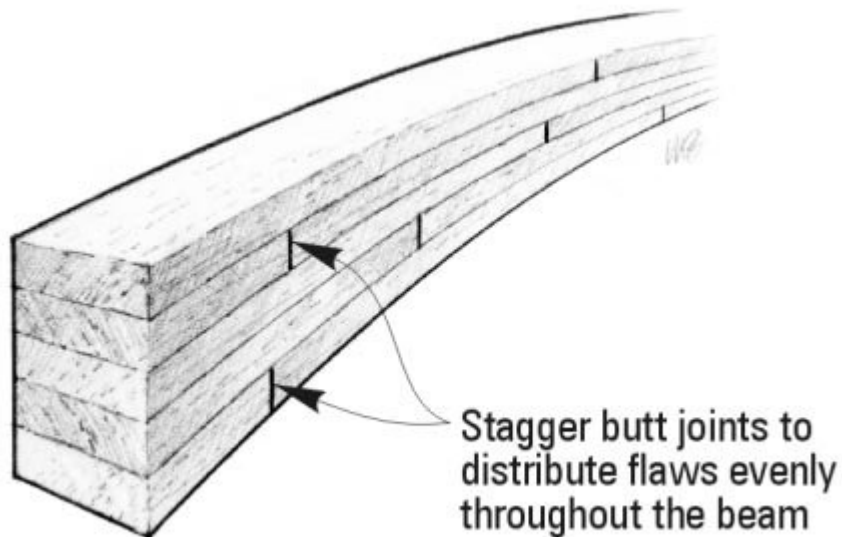

Often it makes sense to place high-modulus/high-strength wooden plies, such as ash or mahogany, furthest from the neutral axis (top and bottom), and lighter, weaker materials such as cedar or spruce in the center. This method puts the stronger, heavier materials where the loads are the greatest and lighter materials where the loads are less, much like building an I-beam. It offers greater strength with less weight.

2. Customizing laminates by visually grading veneers or selecting light and dark layers for aesthetics.

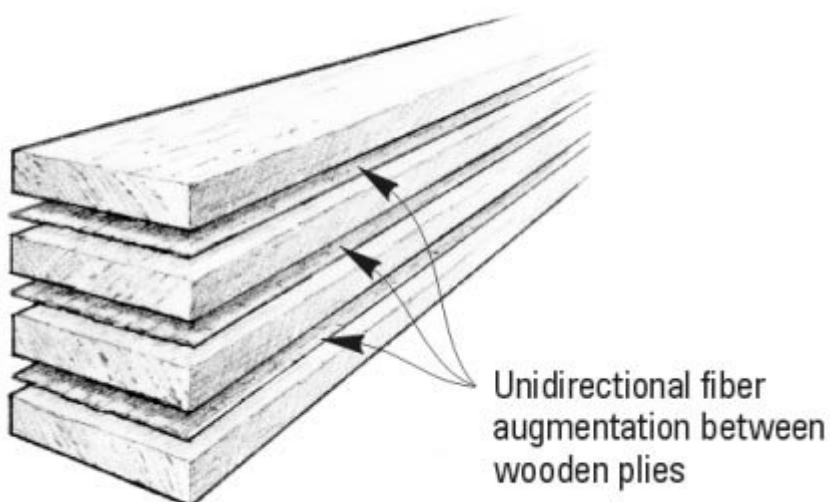

Because wood has a number of natural flaws, it is wise to take precautions to reduce or diffuse them with a grading procedure. After a board has been ripped into thinner plies, flip alternate pieces end-

for-end. On important structural components, lay the plies out and visually locate flaws (knots, grain run out or irregular grain pattern) and eliminate them if they are excessive, or spread them evenly throughout the total laminate. You can also separate plies by weight or color and use the best one for the top and bottom plies. For aesthetics, many people like to alternate light and dark colored woods-alternating ash and mahogany, for example.

3. Augmenting laminations with man-made reinforcing fibers for strength.

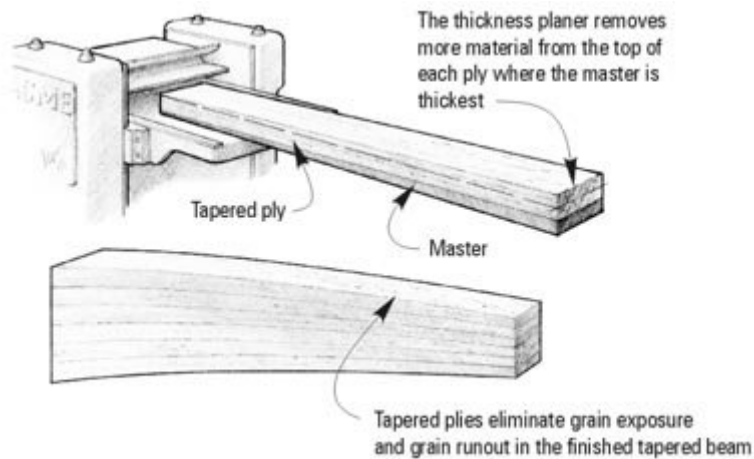

A good way to beef up a unidirectional wood laminate is to augment plies with unidirectional synthetic reinforcing fibers-fiberglass, carbon, Kevlar-adding considerable strength with a minimum weight gain. Strength can be improved further by placing these materials away from the neutral axis of the beam.

Laminates with good cross-grain strength can be created by skewing plies of unidirectional fibers or by incorporating woven or bi-axial fabrics to give the laminate cross-grain reinforcement without significantly increasing laminate thickness.

4. Tapering individual plies can eliminate endgrain exposure and ply runout on tapered laminates.

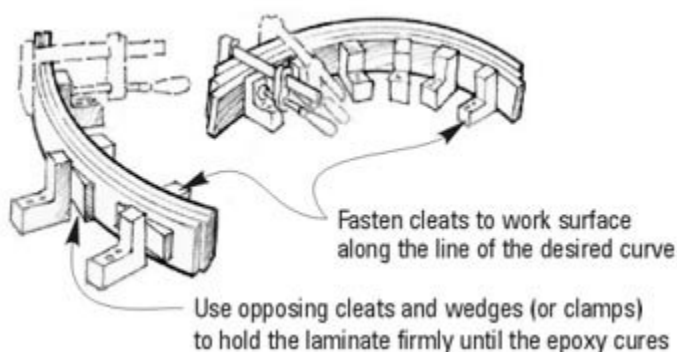

It is tough to taper a laminated beam with saws and planes after it is laminated. A nice approach to use when building tapered beams or beams with tapered ends is to taper individual plies prior to laminating. After the "glue-up," except for cleaning excess adhesive and finishing the sides of the beam, the work is done. In addition to facilitating production, this approach holds the advantage of eliminating exposed endgrain and nearly eliminates grain runout in the taper. It is structurally and aesthetically superior.

To taper the laminates individually, first determine the amount of taper in each ply, from the thickest cross section to the thinnest. Then make a master that is the reverse of each ply. The master will support each ply as it is passed through a thickness planer. The planer will remove the most material from the ply over the thickest part of the master. All of the plies will be tapered identically and when laminated only the sides of the component need finishing.

Forms for curved frames or beams

Layout the desired curved shape of the part onto any flat work surface (a floor or a bench). Attach triangular knees or cleats along one side of the line of the curve. To keep the laminate from bonding to the work surface, place a plastic sheet under the cleats. Attach an additional cleat opposite each cleat on the line. Leave enough space between opposing cleats to easily fit the epoxy-coated plies. When all of the plies are positioned, insert wedges between second row of cleats and the ply stack. Tap the wedges in to clamp the laminate firmly and evenly against the first row of cleats.

Ideally, enough epoxy is applied to all mating surfaces so that a small amount squeezes out as clamping pressure is applied. Even contact is all that is required between mating surfaces-too much clamping pressure only pre-stresses joints and forces adhesive from the joint, which could result in a glue starved joint.

Be careful that the plastic does not find its way between plies when drawing them together. Cover the cleats and clamps with plastic to keep them clean. Spraying mold-release on clamps is also a good idea.

Laminated parts can offer many advantages to the builder. As with most projects, planning ahead is the key to success. A little innovation also goes a long way.